

INSTRUCTION MANUAL



※ Thank you for choosing our high quality cameras.

Before attempting to connect or operate it, please read and follow these instructions.

GENERAL

These CCD video cameras employ a 1/3" SONY CCD solid-state imaging device which provide superior performance.

These cameras can be easily installed in mostly indoor locations along with its very low current consumption of 65mA or less.

These cameras are not only easy to install but achieve an excellent reliability record.

ACCESSORIES FURNISHED

| Accessories | Mounting Bracket | Screw | Instruction Manual |
|-------------|------------------|-------|--------------------|
| Qty | 1 | 3 | 1 |
| Option | - | - | - |

SPECIFICATION

| Signal format | NTSC | PAL |
|--------------------------|---|--------------------------|
| Image Device | 1/3" Sony Super HAD CCD | |
| Effective Pixels | 768(H) × 494(V) | 752(H) × 582(V) |
| Scanning System | 2:1 Inter lace | |
| H.Resolution | 550TV Line | |
| S/N Ratio | More than 45dB (AGC Off) | |
| Gamma Correction | 0.45 | |
| Low Lux Sensitivity | 0.05Lux / Face Plate | |
| White Balance | Auto | |
| Gain Control | Auto | |
| Electronic Shutter Speed | 1/60 ~ 1/100,000sec Auto | 1/50 ~ 1/100,000sec Auto |
| Video Output | Composite 1[Vp - p]75Ω unbalanced | |
| Operating Voltage | DC 12V (± 10%) | |
| Current Consumption | 65 mA or less | |
| Temperature | Operating (-10°C ~ +50°C) / Storage (-20°C ~ +60°C) | |
| Option | Mirror, Digital Day&Night | |
| Lens Option | <ul style="list-style-type: none"> ■ Board Lenses : f 2.45, 2.97, 3.6, 6, 8, 12mm ■ Pinhole Lenses : f 3.7, 4.3mm ■ Door View Lenses : f 1.78mm (only 19φ) ■ f2.97, 3.6, 8, 6, 12mm board lenses only for water resistant | |

Face Plate : Point at the CCD without obstruction of light from any other material.

DIMENSIONS

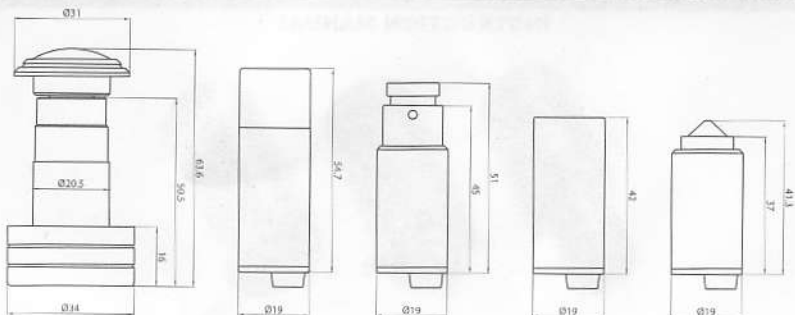

Unit: mm

CAMERA MOUNTING POSITION

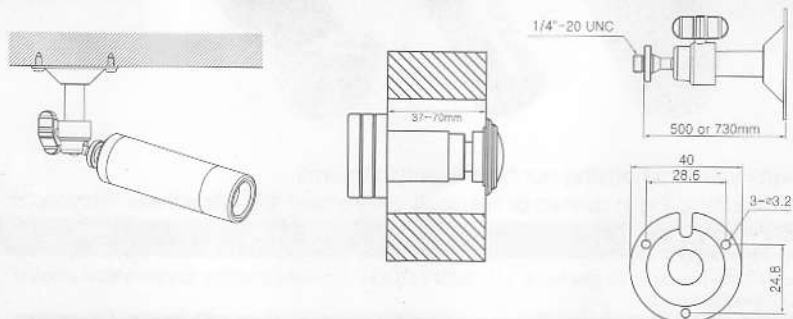

CONNECTION

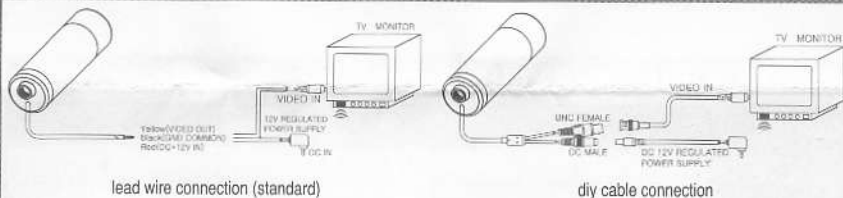

! When you install the camera, please glue up the end of cable to keep it stable in order to protect the camera from the humidity problems.

This device complies with Part 15 of the FCC Rules. Operation is subject to the following two conditions;

1. This device may not cause harmful interference.
2. This device must accept any interference received, including interference that may cause undesired operation.

Note - This equipment has been tested and found to comply with limits for a Class B digital device, pursuant to part 15 of the FCC Rules. These limits are designed to provide reasonable protection against harmful interference in a residential installation.

This equipment generates, uses, and can radiate radio communications.

However, there is no guarantee that interference will not occur in a particular installation. If this equipment off and on, the user is encouraged to try to correct the interference by one or more of the following measures :

- Reorient or relocate the receiving antenna
- Increase the separation between the equipment and receiver.
- Connect the equipment into an outlet on a circuit different from that to which the receiver is connected.
- Consult the dealer or an experienced radio / tv technician for help.

Caution - Any changes or modifications in construction of this device which are not expressly approved by the party responsible for compliance could void the user's authority to operate the equipment.

! caution

1. A regulated DC 12V 300mA power supply is recommended for use with this camera for the best picture and the most stable operation.

An unregulated power supply can cause damage to the camera.

When unregulated power supply is applied, product warranty will be out of subject.

2. It is recommended that the camera is used with a monitor that has a CCTV quality 75 video impedance level.

If your monitor is switched to high impedance then please adjust accordingly.

3. Do not attempt to disassemble the camera to gain access to the internal components.

Refer servicing to your dealer.

4. Never face the camera towards the sun or any bright or reflective light, which may cause smear on the picture and possible damage to the CCD

5. Do not remove the serial sticker for the warranty service